

SECTION A-A

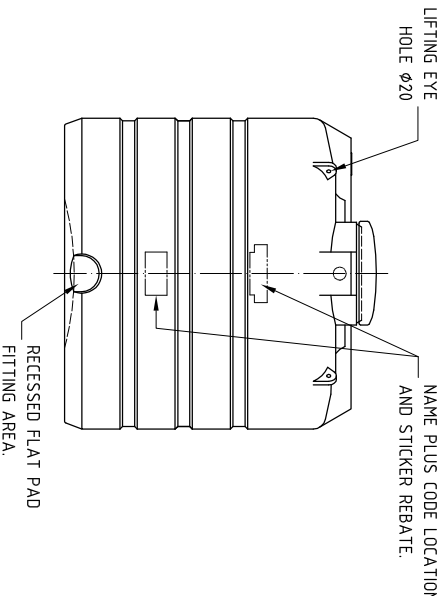

FRONT ELEVATION

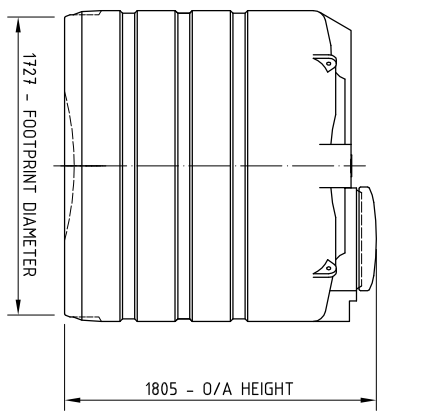

SIDE ELEVATION

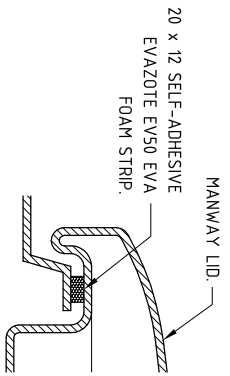

DETAIL 'Y'

- GENERAL NOTES :**
1. TANK IS AVAILABLE WITH FITTINGS WHERE REQUESTED.
  2. ALL DIMENSIONS ARE APPROXIMATE AND ARE FOR INFORMATION ONLY.
  3. ALLOW FOR EXPANSION WHEN TANK IS FULL.
  4. SITE FOUNDATIONS TO ACCOMMODATE WEIGHT OF TANK PLUS CONTENTS.
  5. ENSURE ALL EXTERNAL PIPEWORK IS FULLY & INDEPENDENTLY SUPPORTED.

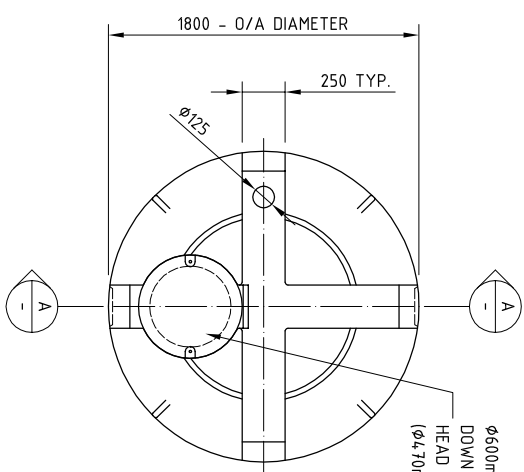

PLAN VIEW

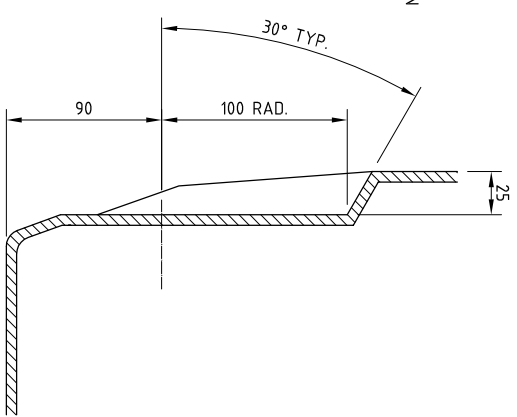

DETAIL 'X'

01	FIRST ISSUE	KG	BB	BB	31/08/11
ISSUE	MODIFICATION	BY	CHK	APV	DATE

**BALMORAL TANKS**

Balmoral Park, Ioriston, Aberdeen AB12 3QV, Scotland  
 Telephone +44 (0)1224 899000 Fax +44 (0)1224 899059  
 E-mail [group@balmoral.co.uk](mailto:group@balmoral.co.uk)



THIS DRAWING IS COPYRIGHT AND IS ISSUED ON CONDITION THAT IT IS NOT COPIED, REPRODUCED OR DISCLOSED TO A THIRD PARTY WITHOUT CONSENT IN WRITING OF BALMORAL GROUP LTD., ABERDEEN



FIRST ANGLE PROJECTION



THIRD ANGLE PROJECTION

ALL DIMENSIONS IN MILLIMETRES UNLESS STATED OTHERWISE - DO NOT SCALE IF IN DOUBT - ASK

TANK RANGE  
**WATER STORAGE TANKS**

DRAWING TITLE

**3635 - GENERAL ARRANGEMENT WITHOUT FITTINGS.**

DRAWN BY	CHECKED BY	APPROVED BY	DRAWING No.
K. Gibson	B. Bakewell	B. Bakewell	RT11013-2-11
SCALE	DATE	SHEET SIZE	TYPE
1:30	August 2011	A3	STD. DRG.