

Series 4 Clean Water Pump



*Non-return valve
 Pressure-sensitive
 Dry-run protected
 Sealed electronic controls
 Individually factory-tested
 Twin chamber and pressure release gap*



SAFETY MEASURES

Electric apparatus designed for use in water. Serious injury can arise if instructions are not followed carefully. The pump is not for use by anyone under the age of 16, nor for anyone who has not read these instructions. In the event of malfunction it is important to identify and remedy the causes before switching the pump on again; use the trouble-shooting guide.

- This pump can only be used to pump clean water. It is forbidden to pump oils, explosive or flammable liquids or water with debris particles bigger than 2mm.
- Danger of electric shock: Pump must be connected through an RCD protected mains electric socket to ensure electrical safety. Never install a damaged pump or one with frayed wires. Never use the power cable to support or move the pump; use the handle and the HDPE pipe when connected. Disconnect the pump from the power supply before any work. When handling the pump, while it is connected to the power supply, avoid all contact with water.
- Danger working over underground tanks: Take precautions to avoid falling into, or getting, stuck in, the opening to a tank.
- Danger of water pressure: ensure your face or body is not in line with the pump output when turning the pump on.

UNDERWATER INSTALLATION

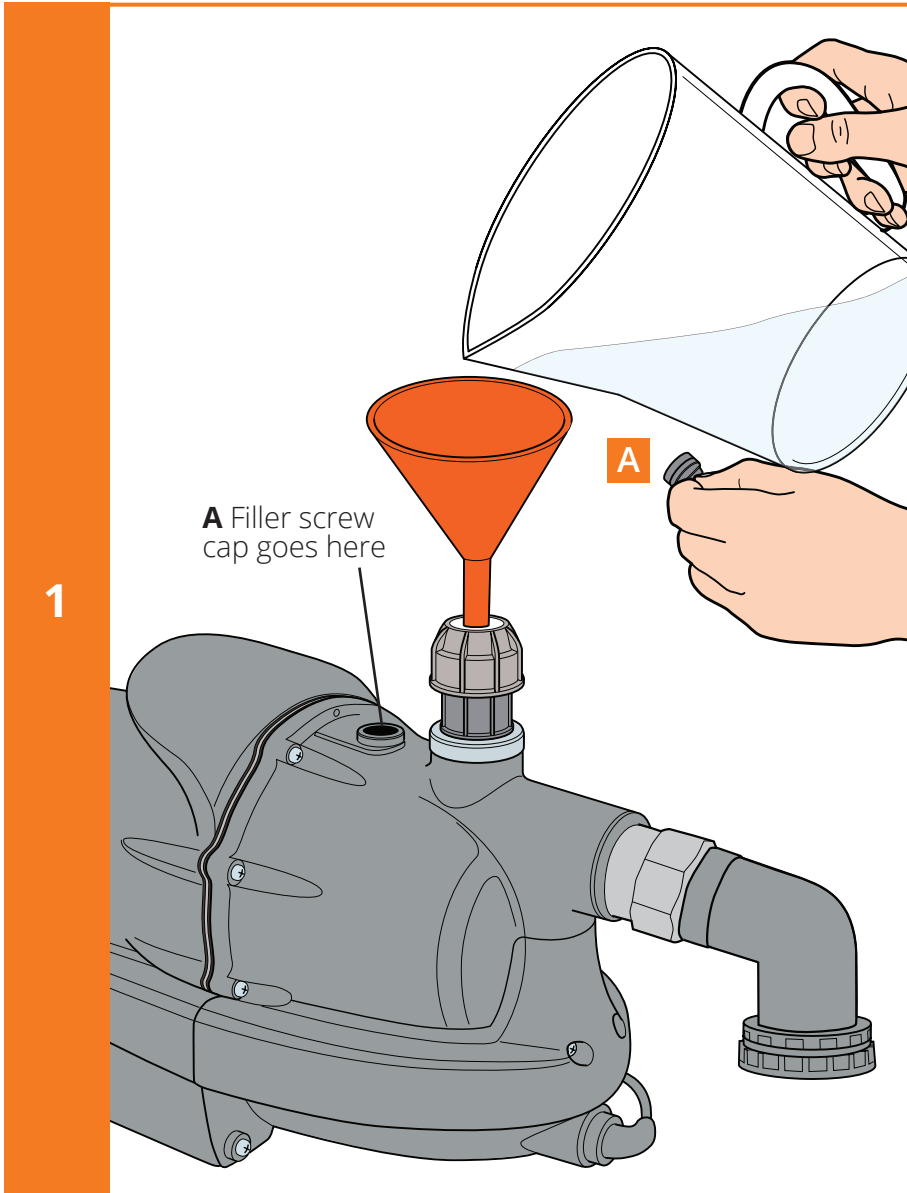

If purchased, connect the optional cartridge filter.

Remove filler screw **(A)**, fill with water (about 2 litres) to prime the pump, and replace tightly.

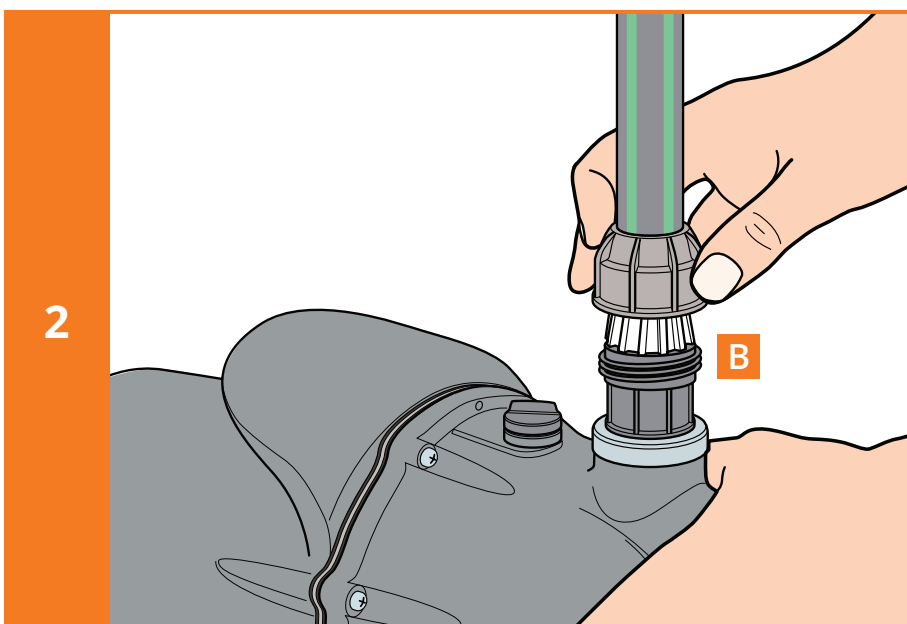

Connect output pipe into the outlet connector **(B)**.

Only cut pipe with pipe cutters and use provided inserts **(E)** in the pipe.

UNDERWATER INSTALLATION

3

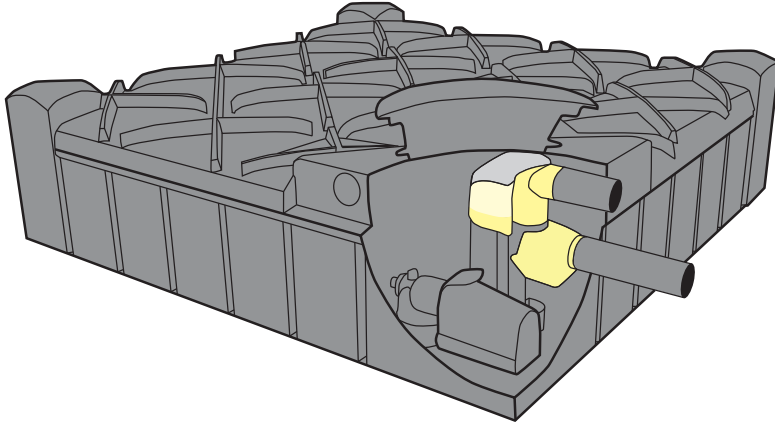

Ensure pump is seated level on the floor of the tank.

Take care to check that all the pipe connections are tight and that there are no leaks otherwise the pump will not be able to pressurise itself.

4

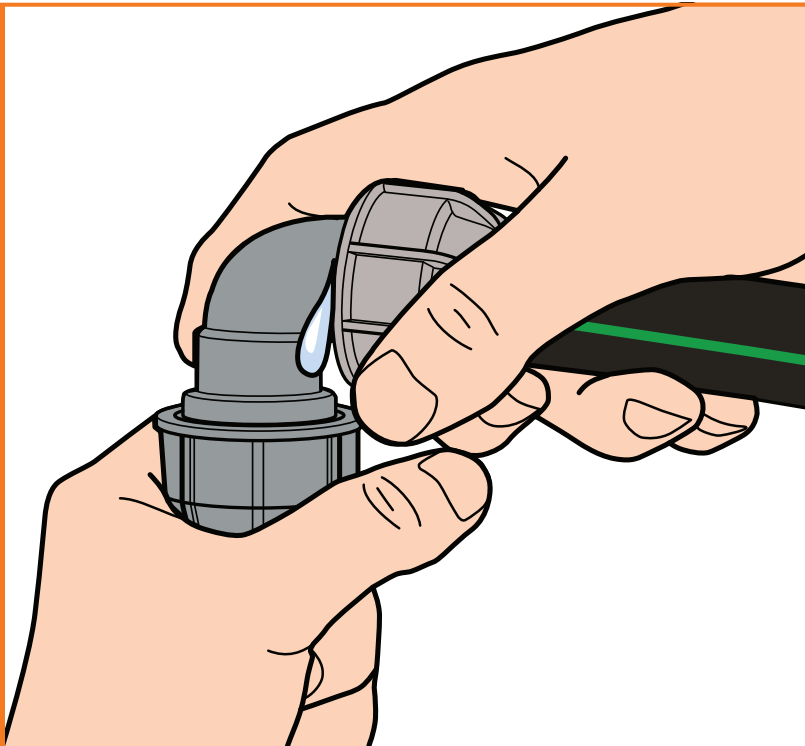

Turn pump on at the mains to ensure it runs and has no leaks at any of the connections, and turns off when all outlets are closed.

The pump can be left plugged in all of the time.



Complete Below Ground Installation



Complete Above Ground Installation

ABOVE GROUND INSTALLATION

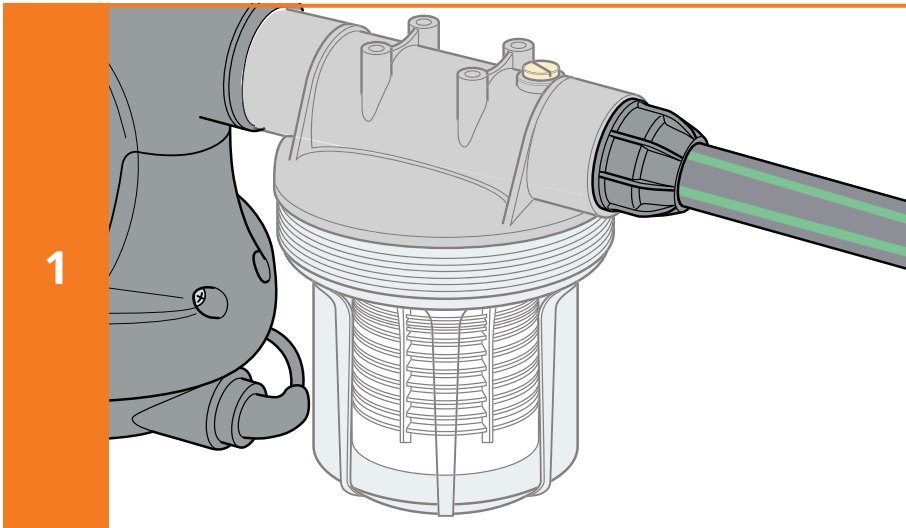

If being used, connect your input pipe and optional cartridge filter (neither supplied) to the pump inlet which has a 1" BSP male thread.

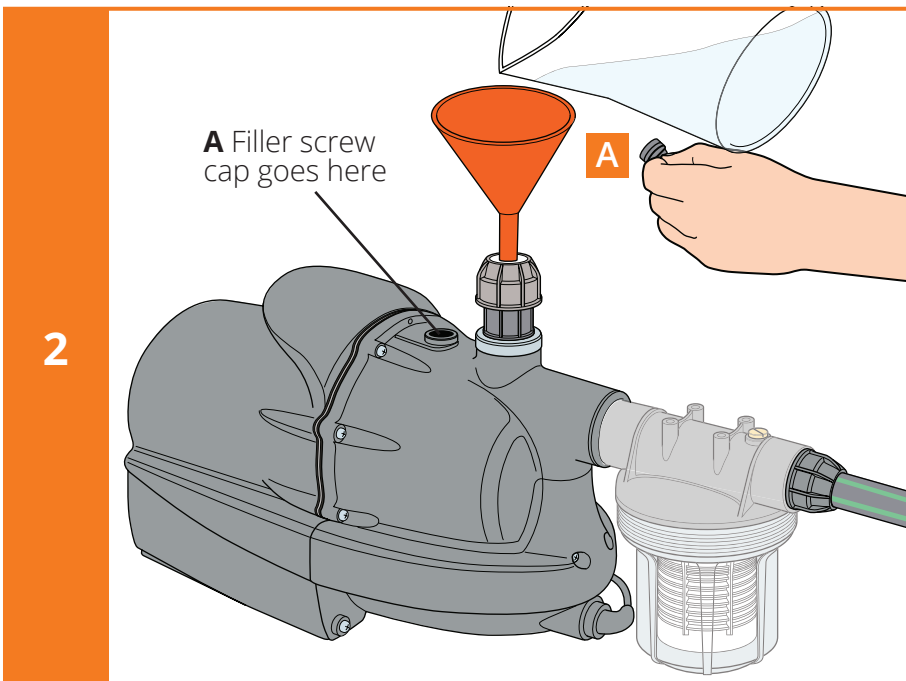

Remove filler screw (A), fill with water (about 2 litres) to prime the pump, and replace tightly.

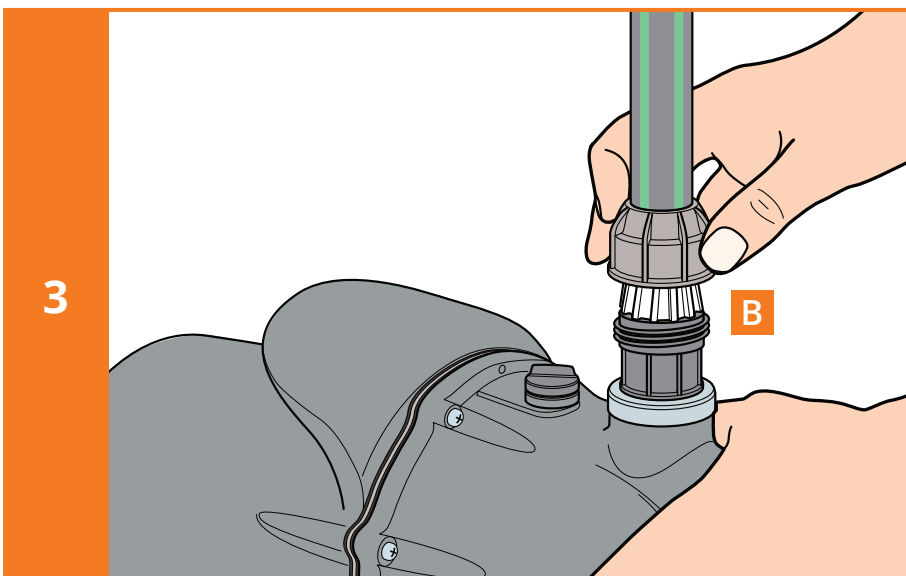

Connect output pipe into the outlet connector (B). Only cut pipe with pipe cutters and use provided inserts (E) in the pipe.

ABOVE GROUND INSTALLATION

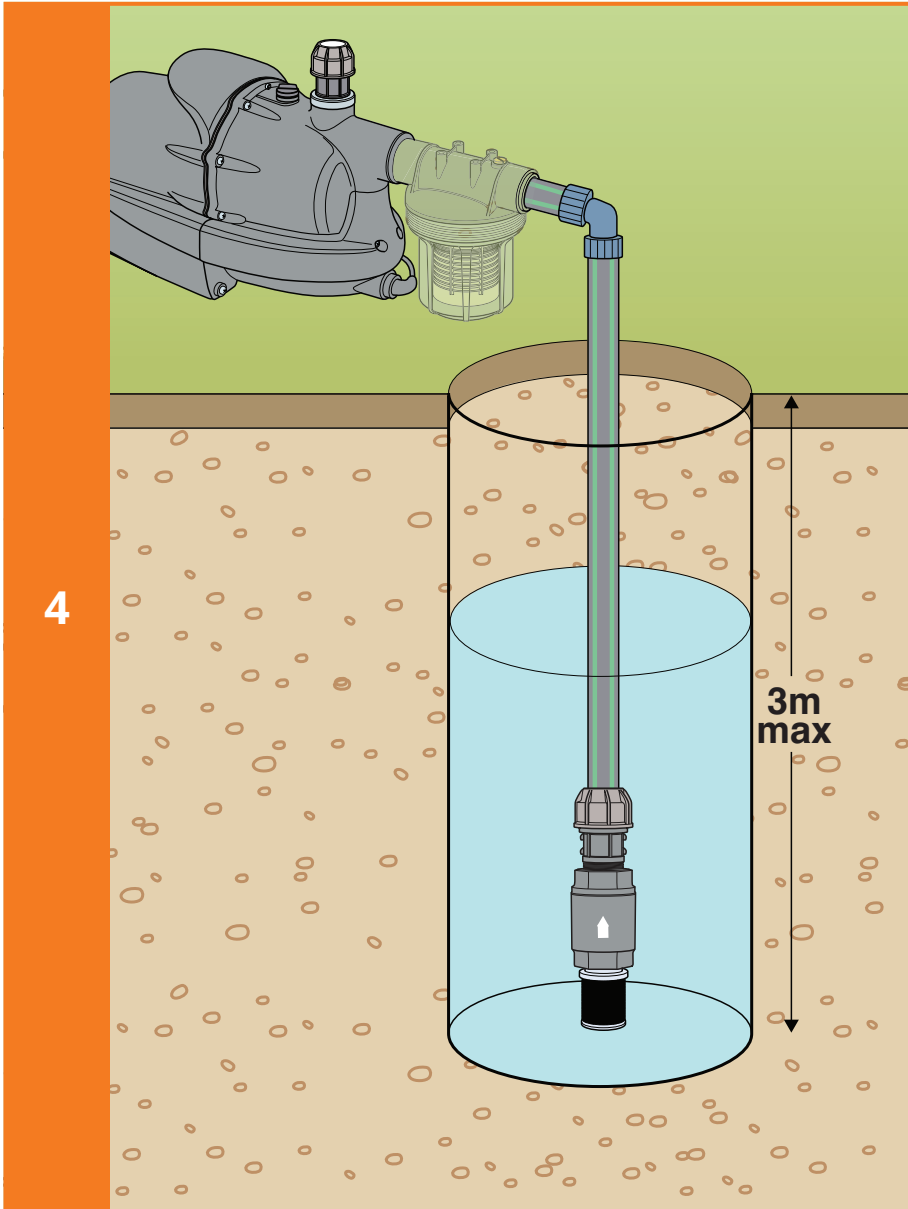

If the pump is drawing water from a lower level, fit a non return valve (not supplied) on the inlet pipe at its lowest point. Prior to first pumping, fill the pipe with water.

Use PTFE tape on all fixings. Maximum draw is 3 metres vertical.

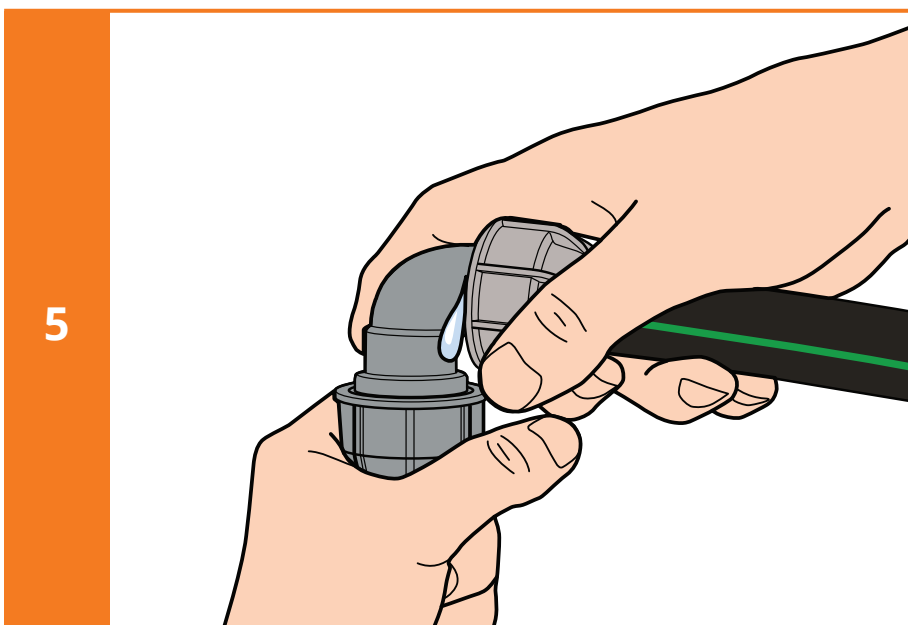

Turn pump on at the mains to ensure it runs and has no leaks at any of the connections, and turns off when all outlets are closed.

The pump can be left plugged in all of the time.

WHAT'S IN THE BOX?

Please check all components:

A	Filler Screw	
B	Outlet Connector	
C	Inlet Connector	
D	Electric cable	
E	Pipe inserts x 3	



A Filler Screw

B Outlet Connector
for HDPE pipe

C Inlet Connector

E Pipe Inserts x 3

D Electric cable

TECHNICAL TERMS:

- 1. Priming:** pump must have water in it before first start. Remove the filler screw, pour water into the body of the pump until full (about 2 litres) and replace the screw.
- 2. Dry run protection:** pump will stop if no water pressure and its reset automatically (see specifications on back page). Also, as a failsafe, if the pump motor overheats the motor is turned off till it cools.
- 3. Pressure-sensitive:** pump runs when water is demanded and stops when taps or appliances are turned off.
- 4. Reset:** in rare cases disconnect the mains electricity and reconnect after 15 seconds to make the pump run again.
- 5. Hunting:** pump turns on and off repeatedly due to a leak somewhere in the output piping. Check all connections for leaks and make sure they are tight.
- 6. Leak Protection:** if the pump detects there is a leak or very slow flow (less than 8 litres a minute), it will go into a protection mode that can be reset by resetting the pump.

TROUBLE - SHOOTING

SYMPTOM	PROBABLE CAUSE	SOLUTION
1. Reduced water flow/pump pulsing.	Suction pipe, delivery pipe or inline optional cartridge filter obstructed. Restriction on the output.	Disconnect the pump from the power supply before any work. Remove obstructions, clean filter. Ensure the pump can deliver water at least 8 Litres per minute.
2. The pump motor does not run.	No electric power being delivered to the pump. Pump has detected a leak and has gone into leak protection mode. Pump has detected a lack of water and has gone into dry run protection. Pump has overheated (thermal switch has tripped). Pump repeatedly tripping RCD. Non-return valve blocked.	Check the pump is connected to the power supply, fuse has not blown or RCD has not tripped. Identify where the leak may be originating from. Turn off the pump and seal the leak, with special consideration being taken to the underwater connections and reset the pump. Reset the level of water in the tank, turn the pump off at the electrics for 15 seconds, turn on and try again. Make sure pump runs but then turns off when pressurised (see 4). Unplug pump and leave to cool down for half an hour. Switch resets automatically as it cools. Disconnect and contact supplier.
3. The motor runs but no water is supplied.	Air inside the pump or filter body. No water in storage tank.	Prime the pump: remove the filler screw, pour water into the body of the pump until full (about 2 litres) and replace the screw. Pump should have shut down; possible faulty flow sensor. Contact supplier.
4. The pump does not stop after tap or appliances turned off.	Water pressure not being held.	Check all connections (including the underwater connection) are tight and that there are no leaks.
5. The pump stops and starts intermittently.	Small leak in pipe.	Check all pipe work for leaks especially at pump outlet. All joins after pump should have PTFE tape, but not the joins at the inlet (risk of debris).

If trouble-shooting does not rectify the fault, please complete all the tests and solutions in the trouble-shooting table and prepare the following information before contacting your supplier.

- 1) Note the pump's type number and serial number on side of pump.
- 2) Was the pump primed before first use (black filler screw removed and body filled with water (about 2 litres) with a funnel)?
- 3) Is the water in the storage tank clean, is the optional cartridge filter on the input (small end) side of the pump clean and is water flowing?
- 4) If there is a garden tap connected to your HydroForce™, turn the pump switch on and open the tap. Check whether the tap flows readily and without hesitation. Leave the tap open with a hosepipe to a safe part of the garden or back into the tank for 1 minute. Note if the pump stops, if so, after how many seconds. If there is no garden tap do the

same test by disconnecting the 90° elbow joint from the pump in the turret of the tank (be careful not to let washers fall into the water).

- 5) With the top of the underground tank open, turn off the tap. Count the seconds till the pump turns off; it should be between 2 and 10 seconds.
- 6) Check for any other reason why supply of water to the pump is restricted. Is the bottom of the tank very dirty? Could dirt be getting into the pump?
- 7) Shut off tap, observe pump stopping. Ensure it does not start again or hunt within 15 minutes.

Background to the workings of "pressure-sensitive" pumps:

Pump motor starts: Pump switches on when i) a drop in pressure is detected by the pressure switch in the bottom of the pump, i.e. when tap or appliances are turned on and ii) the non-return valve shows no water flow.

Pump motor stops: Pump switches off when no water flow is detected by the flow sensor in the non-return valve at the water inlet to the pump. This is the case when the tap or appliances are turned off and water flow stops. The pressure sensitive switch does not provide both the on and off functions. Both the non-return valve (with water flow detector) and the pressure-sensitive switch provide input to the logic of the printed circuit board (PCB). The thermal switch, which turns the pump off when temperatures in the motor stator is too high, is not connected to the PCB.

If you continue to have issues please consult our problem solving website at

www.RainHub.co.uk



SPECIFICATIONS

The HydroForce™ Series 4 is an electronically-controlled, pressure-sensitive, submersible, centrifugal roto-dynamic pump with no reciprocating parts.

Inlet port to the pump is 1" (25mm) male BSP.

Output Port: 1 inch (25mm) female BSP provided with push-fit connector for 1 inch (25mm) MDPE pipe (1¼ inch (32mm) connector option by special order).

Dimensions: L 565 W 185 H 260 mm.

Weight: 13.1 kgs.

Max Head: (nominal) 35 metres.

Pump Pressure: (nominal) at outlet 3.5 bar.

Max Suction: 3 metres.

Electrical Use: 220-240 Volts AC at 50Hz, 800 watts requiring 13 amp RCD-protected socket. Cable length 5 metres.

Pressure-sensitive (demand) pump which turns itself off until there is a demand for water.

Dry-run Protection: when no water is detected for 8 seconds, the pump is turned off by the PCB to protect the motor and pump from burning out.

Automatic reset after a period of 30 minutes. If water is still not detected, subsequent reset periods are 10 minutes, 1.5 hours, 3 hours, 6 hours, 12 hours, then every 24 hours until water is detected. Additionally, a thermal switch turns the pump off before the motor overheats. It resets when cooled down, which may take several hours.

Alloy bulkhead, pressure release gap and twin chamber design prevent ingress of water to the motor, electrical components, and to the bearing oil. Double bearing seals prevents egress of bearing oil. Alloy bulkhead dissipates motor heat to water in the second chamber.

Each pump is tested before leaving our factory and there may be marks on the connectors and residual water in the body. Pump serial numbers are on record for each pump and can be recalled in the event of a warranty claim.

For ease of maintenance, it is advised when installing in an underground tank, the pump is connected via an IP66 connection box in the turret of the tank. The connection box must be connected to the RCD via armoured cable run through underground ducting.

Pressure-sensitive pumps are unsuitable for use with low flow applications such as drip feed irrigation systems. To be used on such a system a pressure vessel must be installed and charged to 2.1 bar (30 psi).

WARRANTIES

The HydroForce™ pump is guaranteed for 2 years from the date of purchase for manufacturing faults.

HydroForce™ Pumps Ltd certifies that the Series 4 pump with the model and serial number specified on the nameplate, are compliant with the safety requirements of the Machine Directive 89/392/EC and amendments, of the Low Voltage Directive 73/23/EC and in the Electromagnetic Compatibility Directive 89/336/EC and amendments.

The materials and manufacturing of this product are guaranteed for 2 years from the date of purchase if the installation instructions are complied with, the pump has been used for its designed applications and it has not been disassembled.

It is obligatory to prime the pump by removing the Filler screw and filling the body of the pump (approx. 2 litres of water) then replacing the Filler screw. In the event of an apparent fault, the retailer or installer should be contacted first. HydroForce™ Pumps Ltd declines responsibility for incidents or damage caused by negligence or by ignoring these instructions. Never use the power cable to support or move the pump; use the handle and the nylon cord.



HydroForce™ Pumps Ltd,
Unit A Harrier Park, Southgate Way,
Orton Southgate, Peterborough,
England, PE2 6YQ

Tel: +44 (0)1733 405 111

www.HydroforcePumps.co.uk

Email: info@HydroforcePumps.co.uk